

SMOKEMASTER®

High Efficiency Electronic Air Cleaner Model X-400



The X-400 features the 'Coanda' 4-way airflow pattern.

Coanda Air
Pattern

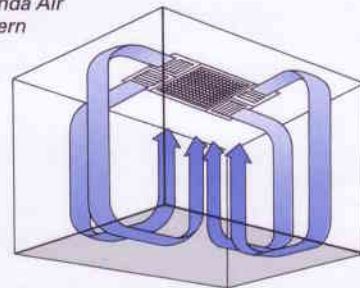

- Totally self-contained air cleaner.
- Ultimate 'flush with ceiling' mounted workhorse.
- Features industrial-rated electronic filtration cell.

Superior performance and time tested design makes the Smokemaster® an excellent choice for removing tobacco smoke, pollen, mold spores and dust.

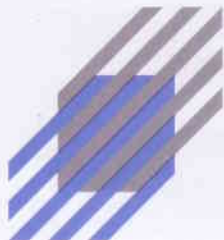

AIR QUALITY
ENGINEERING

Manufacturer and Worldwide Distributor of Air Cleaning Systems for Over 30 Years

X-400 FEATURES & SPECIFICATIONS



Smokers like clean air, too!

The Model X-400 Electronic Air Cleaner:

- Comprehensive
- Inconspicuous
- Economical
- Quiet
- Assures your indoor air quality

FEATURES & BENEFITS

- **High Efficiency** - Removes dust, smoke, pollen and other particles using high efficiency electronic collector cells.
- **Inconspicuous** - The attractive grille fits flush with the ceiling and is completely inconspicuous! The cabinet is hidden in the unused space above the ceiling.
- **Quiet** - Three-speed controller is standard and allows for quiet operation without sacrificing effectiveness. It's ideal for private offices, conference rooms or other areas where noise levels may be a factor.
- **Easy Installation** - Special-mounting brackets simplify the installation and do not require any additional space above cabinet height of 13 5/8".
- **COANDA Airflow** - Effective 360° COANDA airflow gently and evenly distributes clean air and returns dirty air to the unit. COANDA airflow de-stratifies air and eliminates "stuffy" air pockets.
- **Economical** - Permanent electronic collector cells assure low operating cost by eliminating costly filter replacements. Moreover, because collector cells offer no airflow restriction, only limited horsepower is necessary, thus reducing noise and electrical draw.
- **Comprehensive** - Two activated carbon filters for odor control included.

Electronic Air Cleaning



HOW THE X-400 WORKS

Contaminant particles, such as those in tobacco smoke, receive an electrical charge as they pass into the electronic cell and are then attracted to oppositely charged collector plates, where they are held, similar to the way that metal filings collect to a magnet. The air vent provides dilution control of gaseous contaminants. Standard activated carbon filter adsorbs odors and gases to further freshen the air.

SPECIFICATIONS / MODEL X-400

Electrical Rating:	120V / 60 Hz
Low Speed:	175 CFM / .4 Amps
Medium Speed:	275 CFM / .6 Amps
High Speed:	400 CFM / .8 Amps
Color:	White
Motor:	.05 Hp Thermally Protected
Dimensions:	24" x 24" x 13 5/8"
Installed Weight:	44 Lbs.
Shipping Weight:	54 Lbs.
Primary Filter Collection Area:	52.9 Sq. Ft.
Sorbent Media:	2 Carbon Post Filters
Air Cleaning Efficiency:	Up to 99.7% (ASHRAE 52.2)
Optional Accessories:	<ul style="list-style-type: none"> • Remote Fan Speed Control • Electronic Cell Wash Tank • Cell Cleaner Concentrate

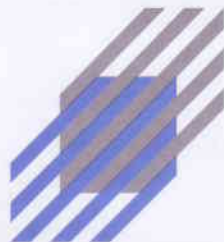
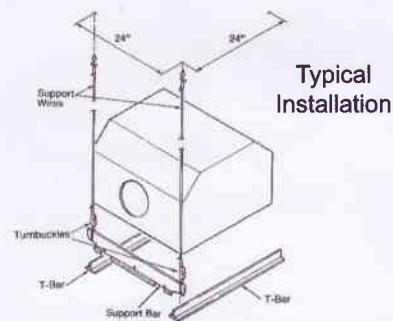

**AIR QUALITY
ENGINEERING**

7140 Northland Drive North, Brooklyn Park, MN 55428-1520 USA

FAX: (763) 531-9900 EMAIL: aqe@isd.net WEB SITE: www.air-quality-eng.com
TOLL FREE: 1-800-328-0787

Air Quality Engineering, Inc., has a policy of continuing product improvement, and reserves the right to make changes in design and specification without notice.